

OCEAN ELEVATORS

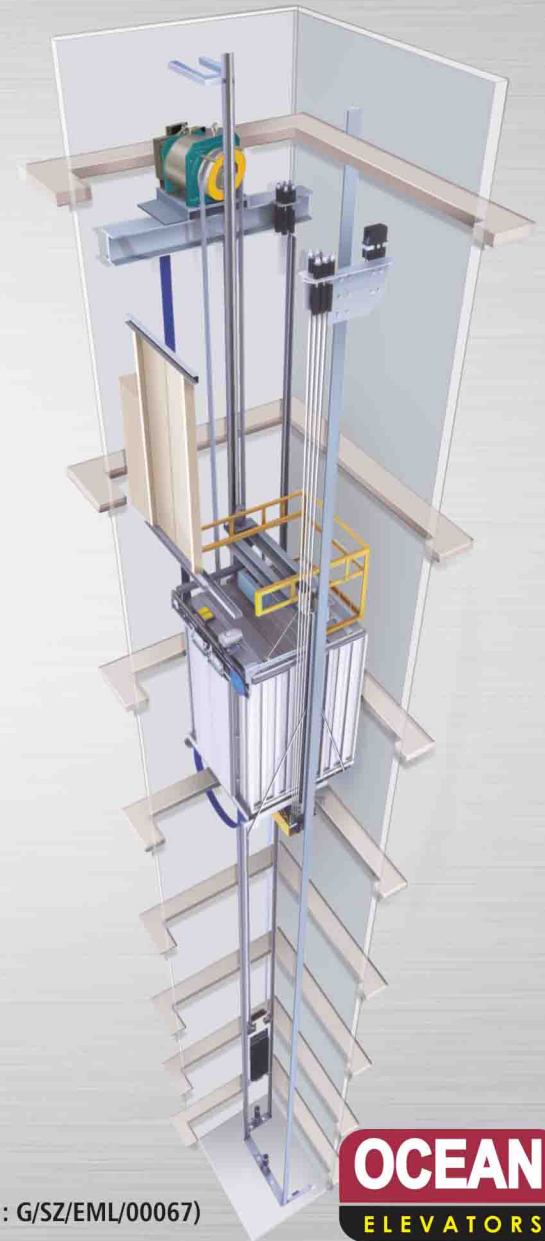

*The Stylish way to
Brand your Elevator*



(ISO 9001 : 2008 / REGD : G/SZ/EML/00067)



Client List

WHITE HOUSE	- ANKLESHWAR	- G+4 MANUAL
SWETH RESIDENCY	- ANKLESHWAR	- G+4 MANUAL
SWARNASHILA RESIDENCY	- ANKLESHWAR	- G+4 MANUAL
SANSKRUT RESIDENCY	- ANKLESHWAR	- G+4 MANUAL
SURYA PALACE	- ANKLESHWAR	- G+4 MANUAL
RIVERA HOUSE	- ANKLESHWAR	- G+4 MANUAL
SHYAM VILLA CO OP HOUSING	- ANKLESHWAR	- G+4 MANUAL
CHINTAN RESIDENCY	- ANKLESHWAR	- G+4 MANUAL
SHUBH RESIDENCY	- VARACHHA	- G+5 MANUAL
SARTHI HEIGHTS	- PUNAKUMBARIA ROAD	- G+6 AUTO DOOR
SHIV DHARA RESIDENCY	- KIM	- G+5 MANUAL
KANYASI VILLAGE	- KIM KANYASI VILLAGE	- G+3 HYDROLIC LIFT
BODHAN	- BODHAN VILLAGE	- G+3 HYDROLIC LIFT
DOCTOR DENTAL CLINIC	- PARLE POINT OPP. SARGAM SHOPPING CENTER - G+2 MANUAL	
YOGI KRUPA RESIDENCY	- NAVSARI	- G+3 MANUAL
MAHAVIR HEIGHTS	- AMROLI	- G+13 MANUAL
RADHEY RESIDENCY	- AMROLI	- G+12 MANUAL
CHARBHUJA ARCADE	- AMROLI	- G+5 MANUAL
ABHINANDAN RESIDENCY	- PAL ADAJAN (C & D BOCK)	- G+5 MANUAL
ADINATH FURNITURES GODOWN	- UDHNA BAMROLI ROAD	- G+3 MANUAL
AMAN AVENUE	- KOSAMBA	- G+6 MANUAL
RADHA KRISHNA SOCIETY	- PIPLOD	- G+3 HYDROLIC LIFT
HOTEL ARBAYIN	- NR. GUJARAT COLLEGE AHMEDABAD - G+6 AUTOMATIC LIFT	
HIRA BAJAR	- HIRA BAJAR	- G+5 MANUAL
LIMBAYAT		- G+4 MANUAL
SAPURA PALACE	- RAMPURA	- G+5 MANUAL
JAI MATAJI RESIDENCY	- RAMPURA	- G+5 MANUAL
DURGESH	- RAMPURA	- G+5 MANUAL
KHODIAR ARCADE	- RAMPURA	- G+5 MANUAL
JAY AMBAY RESIDENCY	- RAMPURA	- G+5 MANUAL
SAI DARSHAN	- RAMPURA	- G+5 MANUAL
MELODY	- RAMPURA	- G+5 MANUAL
DEEP INCLAVE	- ICHHAPUR	- G+5 MANUAL
MRL BHANGLOW	- MRL BHANGLOW	- G+3 MANUAL
BHANGLOW LIFT	- ALTHAN	- G+2 MANUAL
CITIZEN HOTEL	- SURAT STATION	- G+4 MANUAL
UNITED FAMILLESH MEMORIAL ASLAF	- HOSPITAL GOODS LIFT VESMA	- G+3 MANUAL
GALAXY HERITAGE	- UNN PATIA SURAT	- G+11 AUTO DOOR
PARLE POINT	- BHANGLOW LIFT	- G+3 AUTO DOOR HYDRAULIC LIFT
PARVAT PATIA	- BHANGLOW LIFT	- G+3 MRL AUTODOOR
CHOUTA BAZAR		- G+4 GOODS LIFT
JANTA GUEST HOUSE	- CITY LIGHT	- G+4 AUTOMATIC HYDROLIC
ASTHA MANGAL	- AHMEDABAD	- G+5 MANUAL
PADAM MARKET	- NANPURA	- B+G+4 MANUAL



Company Profile

ABOUT US :

Commenced in the year 2008 in Surat, Gujarat is a prominent Manufacturer and Supplier of Elevators. The widearray of our Elevators includes Passenger Lifts, Drum Type Goods Lift, Goods & Passenger Lift, Hydraulic Scissor Lift, Glass Capsule Lift, Hospital Lift and many more. The company is constantly progressing and developing under the leadership of Mr. Halim, the Director of the company. The operation of the lift during start, stop and in the running shall be jerk less, smooth and free from vibration. The car operating control panel and panel on landing shall be latest design with Up/Down arrow and floor position indication. The equipment, installation & erection of lift shall be as per I.S. standards. The Bought - out items shall be of I.S. or known make available. We offer our best products & services to our clients .

TEAM WORK :

We consider our team as the backbone of our organization. Owing to our diligent and talented workforce, we are able to stand apart in this competitive industry. It is due to the experience and proficiency of our engineers that we are able to fabricate our range of lifts and elevators as per the technical specifications given by our clients. Apart from engineers, our workforce also comprises of technicians, quality auditors, R&D experts and other administrative staff. Each member of our organization imparts their duty with full commitment and dedication and works in mutual co-operation to ensure that the resources are fully utilized and end products are technically sound. We also arrange for skill enhancement sessions that help our employees to be competitive and up-to-date with the technological advancements.

QUALITY ASSURANCE :

Our quality inspectors' keeps stringent vigil over the entire processes right from the procurement of raw material till the final delivery of lifts and elevators. Various tests are also conducted on our products to ensure that only flawless products move from our end. Following are some of the factors on parameters, based on which the final inspection is carried on: Reliability, Maintainability, and Safety.



CUSTOMER SATISFACTION :

Our clients are spread across the parts of the Gujarat. Our multiple ranges of lifts and elevators have received a lot of appreciation from our quality conscious clients. Working with goal of utmost customer satisfaction, we have aligned all the activities in our organization that enable us to process bulk orders of clients within specific time frame. Our efforts stimulate us to maintain a good professional relationship with our customers.

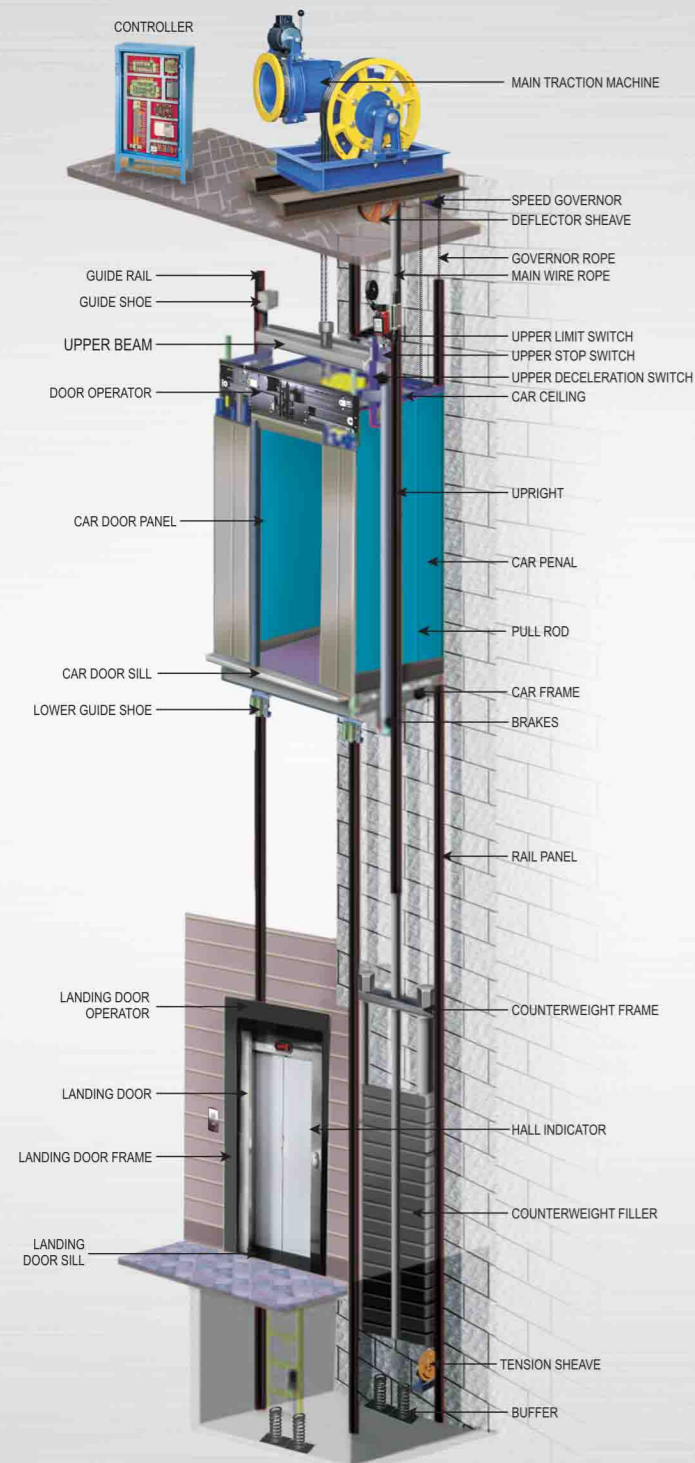

Our Product Range

ELEVATORS TYPE

Manual Passenger & Auto Door Elevators
 Capsule Panoramic Elevators
 Hospital & Goods Elevators
 Dumbwaiters & MRL Auto Door Elevators
 Home & Hydraulic Elevators

RANGE OF MANUAL DOOR

M.S. Collapsible & Imperforated Door
 M.S. / S.S. Swing & Telescopic Door

RANGE OF AUTOMATIC DOOR

M.S. / S.S. Swing Door
 M.S. / S.S. Telescopic Automatic Door
 M.S. / S.S. Center Opening Automatic Door
 S.S. Designed Finished Automatic Door
 Titanium Gold Finish Automatic Door
 Glass with S.S Framed Automatic Door

CAR FINISH

MS Powder Coated Car
 S.S. Hairline / Mirror Finish Car
 S.S. Designed Finish / Titanium Gold Finish Car

ELEVATOR CONTROLLERS

Microprocessors Panel
 V3F Microprocessors Panel
 MRL Microprocessors Panel
 Automatic Rescue Device (ARD)
 Variable Voltage Variable Frequency Device
 Overload Sensor

PUSH BUTTONS & DISPLAY

Surface Micro Push & Touch Button
 Dot Matrix Display & Seven Segment Display
 LCD & LED Display

Comfortable,
 Quiet Ride,
 Smooth
 Door Operator



Passenger Elevator

Manual Door



Passenger Elevator

Manual Door



MANUAL S.S. TELESCOPIC DOOR

MANUAL M.S. TELESCOPIC DOOR



IMPERFORATED DOOR

MANUAL M. S. COLLAPSIBLE DOOR

GLASS VIEW M.S. / WODDEN SWING DOOR

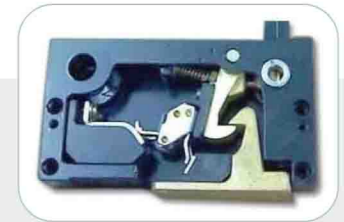
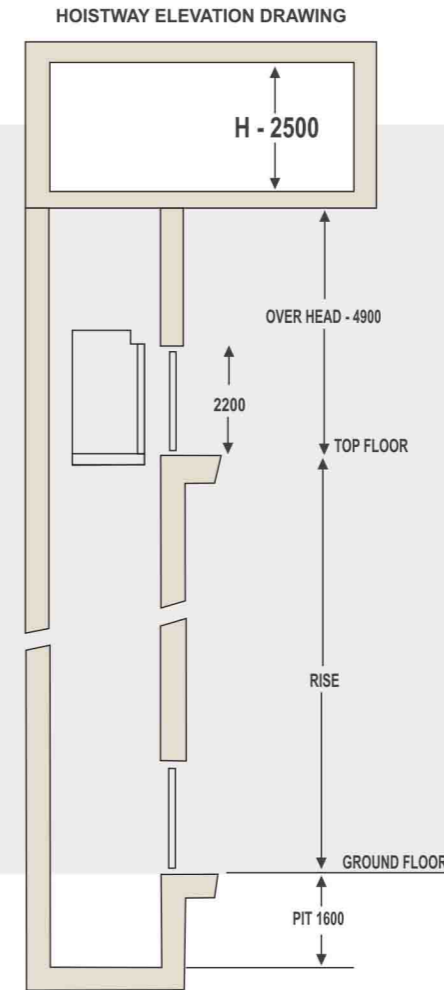
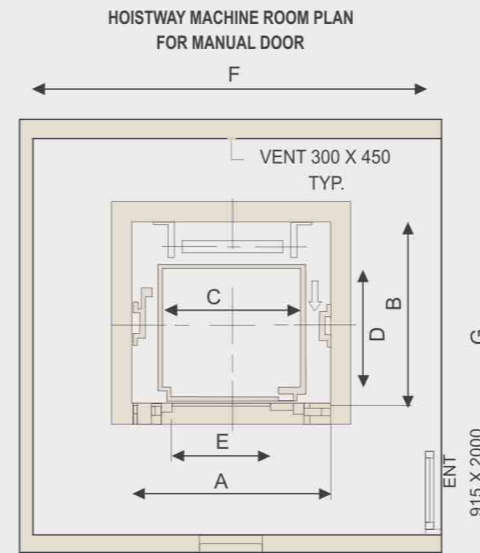

Manual Gate Lock

LOAD		LIFT WELL		CAR INSIDE		ENTRANCE	MACHINE ROOM		
PERSON	WEIGHT IN KG	WIDTH A	DEPTH B	WIDTH C	DEPTH D	E	WIDTH F	DEPTH G	HEIGHT H
4	272	1600	1250	1100	700	700	3000	3000	2500
5	340	1600	1300	1100	850	850	3000	3200	2500
6	408	1670	1370	1100	1000	750	3000	3500	2500
8	544	1800	1600	1300	1100	750	3200	3500	2500
10	680	1850	1800	1350	1300	1000	3500	4000	2500
13	884	2500	1600	2000	1100	1000	4000	4200	2500
16	1088	2500	1800	2000	1300	1000	4500	4800	2500
20	1360	2500	2050	2000	1550	1000	5000	5000	2500

All Dimension are in mm.
This is General Data, it may be change without notice
All hoist way walls should be minimum 230 mm brick or 150 mm R.C.C



Speed : 0.65 to 1 mt / ps
Capacity : 04 to 30 Passenger

Manual Passenger Elevator for Economically Suited All Type of Residential & Commercial Building Depending Upon The Shaft Size With Speed / Amenities Upto Choice of Owners.



Passenger Elevator

Automatic Door

Passenger Elevator

Automatic Door

The Stylish Way to
Brand Your Elevator



S.S. TITANIUM GOLD FINISH AUTO DOOR



MS POWDER COATED TELESCOPIC AUTO DOOR



S.S. CENTER OPENING AUTO DOOR



GLASS WITH SS FRAME AUTO DOOR



STAINLESS STEEL FRAMED WITH FINISH OUTDOOR

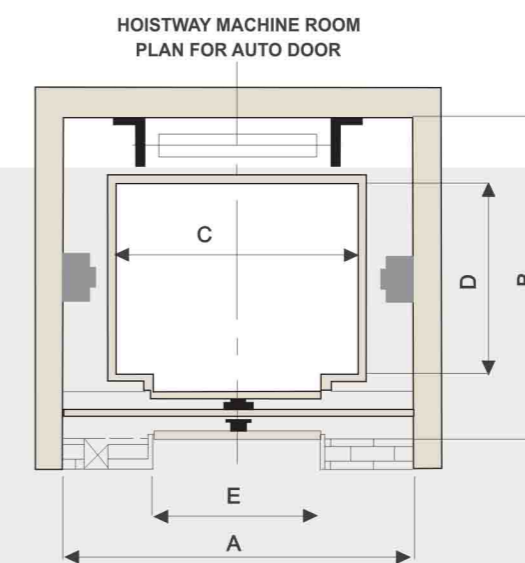
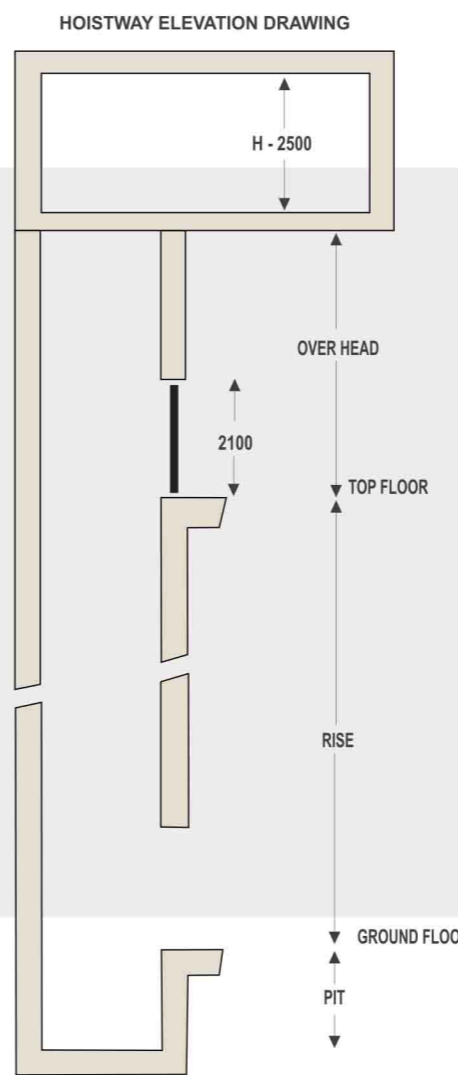

Speed : 0.65 to 1.5 mt / ps
Capacity : 06 to 20 Passenger

Auto Door Passenger Elevator for Residential, Commercial Building, Hotel, Club, & Bungalows depending upon the Shaft Size with Speed or Amenities upto choice of owner

LOAD		LIFT WELL		CAR INSIDE		ENTRANCE	MACHINE ROOM			UPTO 1.5 M/SEC.		UPTO 1.5 M/SEC.	
PERSON	WEIGHT IN KG	WIDTH A	DEPTH B	WIDTH C	DEPTH D	E	WIDTH F	DEPTH G	HEIGHT H	PIT K	O.H. M	PIT K	O.H. M
6	408	1900	1650	1100	1000	800	3000	3500	2500	1600	4800	2600	6700
8	544	1900	1900	1300	1100	800	3200	3500	2500	1600	4800	2600	6700
10	680	1900	2000	1350	1300	800	3500	4000	2500	1600	4800	2600	6700
13	884	2500	1900	2000	1100	1000	4000	4200	2500	1600	4800	2600	6700
16	1088	2500	2000	2000	1300	1000	4500	4500	2500	1600	4800	2600	6700
20	1360	2500	2300	2000	1550	1000	5000	5000	2500	1600	4800	2600	6700

All Dimension are in mm. This is General Data, it may be change without notice. All hoist way walls should be minimum 230 mm brick or 150 mm R.C.C

Capsule Elevator



Capsule Elevator

A New Vision of Elevation

VARIOUS OPTIONS ARE AVAILABLE

Type of Car	One Side View, Three Side View, Half Round View Glass With M.S. Powder Coated Car Glass With Stainless Steel Hair Line Finish Car
Car Finish	Glass With Steel Mirror Finish & Glass With Designed Steel Finish Car Glass With Titanium Gold Designed Finish Car
Door Finish	M.S. / S.S. Center Opening Automatic Door S.S. Designed Finish Automatic Door Titanium Gold Finish Automatic Door Glass With S.S. Framed Automatic Door
Type of Door	Center Opening Auto Door Telescopic Auto Door
Switch Panel Button	Surface Micro Electro Button, Touch Button
Switch Panels Display	Seven Segment, Digital Led Display, Digital Dot Matrix Display, LCD Display

ELEVATOR TYPE

Capsule Panoramic Elevators 90 / 180 / 360 degree view (One side, Three side, Round type with Toughened Glass) lift for Residential, Commercial, Hotels, Club, Bungalows and Building depending upon the shaft size with Speed / Amenities upto choice of owner.

HOISTWAY ELEVATION DRAWING

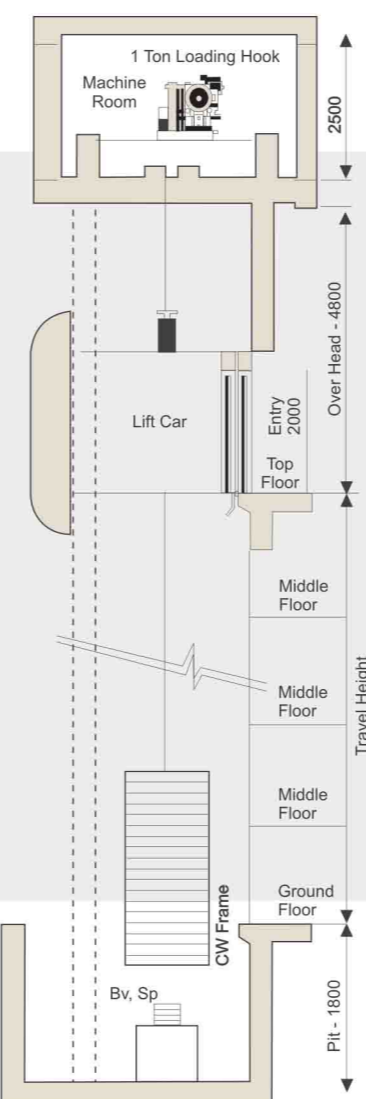

HOISTWAY MACHINE ROOM PLAN

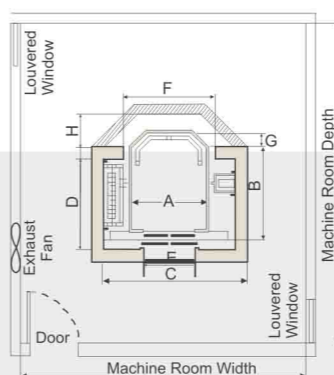

HOISTWAY MACHINE ROOM PLAN

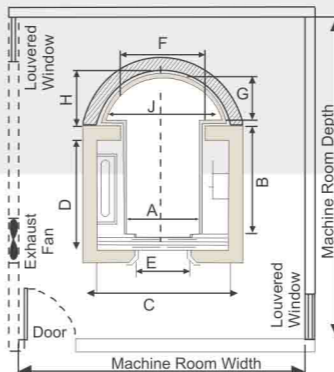

Round Glass Cabin With Stainless Steel Hair Line Finish Car



Glass Cabin



Three Side Glass With MS Powder Coated Car

LOAD		LIFT WELL		CAR INSIDE		ENTRANCE	MACHINE ROOM			UPTO 1.5 M/SEC.		UPTO 1.5 M/SEC.	
PERSON	WEIGHT IN KG	WIDTH A	DEPTH B	WIDTH C	DEPTH D	E	WIDTH F	DEPTH G	HEIGHT H	PIT K	O.H. M	PIT K	O.H. M
6	408	1900	1650	1100	1000	800	3000	3500	2500	1600	4800	2600	6700
8	544	1900	1900	1300	1100	800	3200	3500	2500	1600	4800	2600	6700
10	680	1900	2000	1350	1300	800	3500	4000	2500	1600	4800	2600	6700
13	884	2500	1900	2000	1100	1000	4000	4200	2500	1600	4800	2600	6700
16	1088	2500	2000	2000	1300	1000	4500	4500	2500	1600	4800	2600	6700
20	1360	2500	2300	2000	1550	1000	5000	5000	2500	1600	4800	2600	6700

All Dimension are in mm. This is General Data, it may be change without notice. All hoist way walls should be minimum 230 mm brick or 150 mm R.C.C



Speed : 1.00 to 1.5 mt / ps
Capacity : 06 to 20 Passenger

Hospital Elevator



A Full Range of People and
Good Flo Demanding Medical Facilities

VARIOUS OPTIONS ARE AVAILABLE

Door Finish
 M.S. Collapsible Door
 M.S. Imperforated Door
 M.S. / S.S. Telescopic Manual Door
 M.S. / S.S. Telescopic Automatic Door
 M.S. / S.S. Center Opening Automatic Door



Speed : 0.32 mt / ps
 Capacity : 15 to 30 Passenger

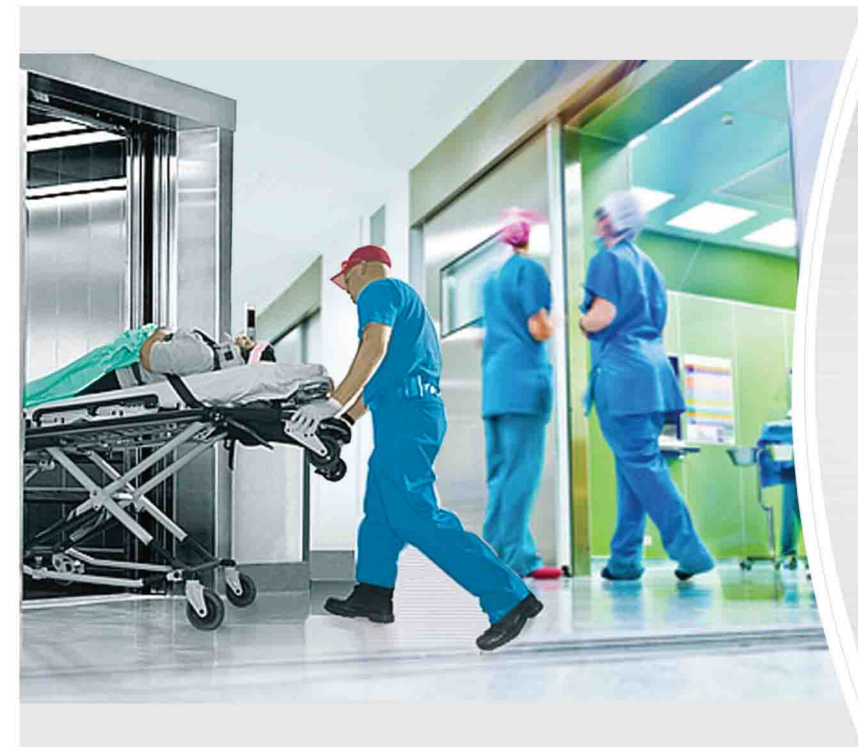

ELEVATOR TYPE

Hospital Stretcher Elevators for Nursing Home and Hospitals Building depending upon the shaft size with Speed / Amenities upto choice of owner.



HOISTWAY MACHINE ROOM PLAN

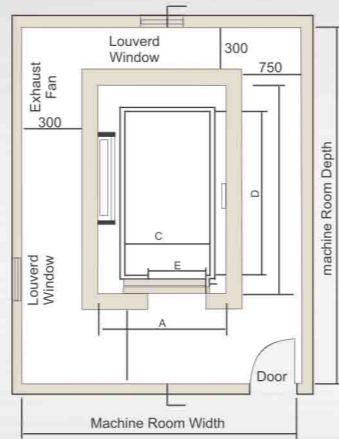

PER SON	CAPA CITY	SHAFT W	SHAFT D	CAR W	CAR D	SHAFT W	SHAFT D	CAR W	CAR D	ENT RANCE
15	1020	1900	3000	1000	2400	1700	3000	1000	2400	800
20	1360	2300	3000	1300	2400	1950	3000	1300	2400	900
26	1768	2600	3000	1600	2400	2100	3000	1600	2400	1000

Collapsible Door Can be Provided if Required, All Dimension are in mm. This is General Data, it may be change without notice. All hoist way walls should be minimum 230 mm brick or 150 mm R.C.C

HOISTWAY ELEVATION DRAWING

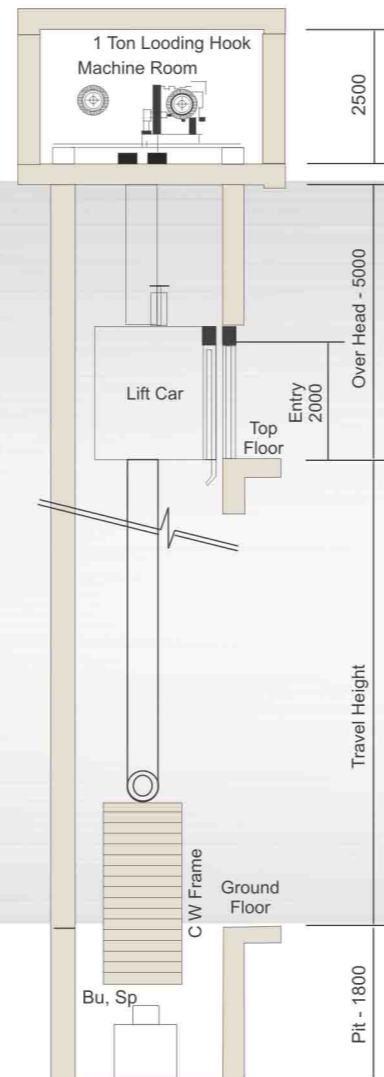

(Section : X-X) Lift Well

Goods Elevator

Your Specialist in Vertical
Good Transport

VARIOUS OPTIONS ARE AVAILABLE

Door Finish
 M.S. Collapsible, Imperforated Door
 M.S. Telescopic Door, S.S. Telescopic Door.
 Goods Elevators for Commercial & Industrial Building depending upon the shaft with Speed / Amenities up to choice of owner



Speed : 0.32 mt / ps
 Capacity : 500 to 5000 Kg. Load.



STURDY AND DURABLE :
Cabin is made of highly intensified shaped materials, able to carry various kind of cargos.

ACCURATE LEVELING :
The Accuracy of Leveling can be controlled with in a scope of several millimeter.

LARGE DOOR WIDTH :
Multiple folded cabindoor structure is employed to reach the max width which facilities the entry of large chrgos

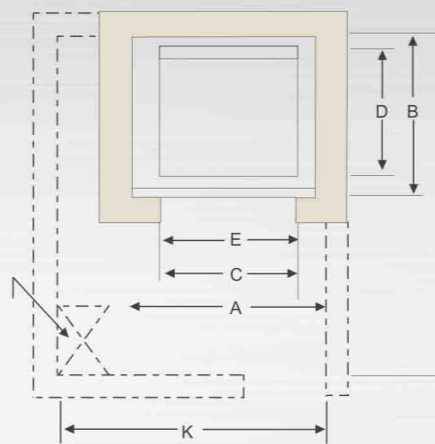
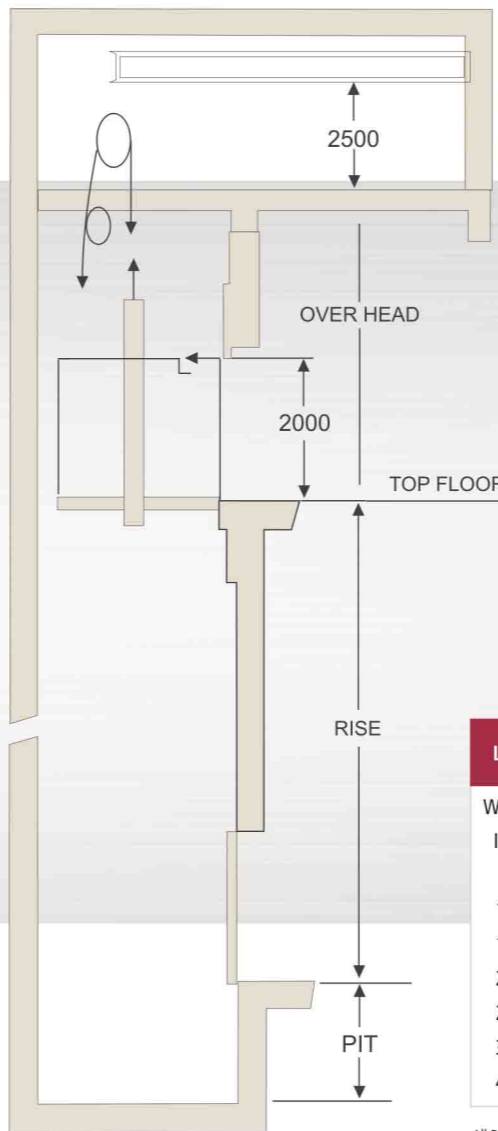

LOAD	LIFT WELL		CAR INSIDE		ENT RANCE		MACHINE ROOM		UPTO 0.7 M / SEC.	
WEIGHT IN KG	WIDTH A	DEPTH B	WIDTH C	DEPTH D	WIDTH E	DEPTH F	DEPTH G	HEIGHT H	PIT K	O.H. M
500	1900	1500	1100	1200	750	3000	3800	2500	1600	4800
1000	2300	2100	1400	1800	1000	3000	4000	2500	1600	4800
1500	2600	2300	1700	2000	1250	3200	4200	2500	1600	4800
2000	2600	2800	1700	2500	1500	3200	4200	2500	1600	4800
2500	2900	2800	2000	2500	1500	3500	4400	2500	1600	4800
3000	2900	3300	2000	3000	2000	3500	4500	2500	1600	4800
4000	3400	3300	2500	3000	2000	4000	4600	2500	1600	4800

All Dimension are in mm. This is General Data, without notice.

MRL Elevator

Machine Roomless Elevator



MRL Elevator

Machine Roomless Elevator

The Revolutionary
MRL Elevator Concept

The Machine roomless elevators incorporate environment concern by using energy saving machines and low noise controller. It also saves construction space which totally reflects the idea of environment friendly culture.

Compared with gear load elevators (having same load capacity), these elevators save about 25% energy and 10% construction area. Roomless passenger elevators have overcome conventional prerequisites of machine rooms by providing limitless possibilities in creation of elevators which confront with optimal space utilization.



Various options are available :

- Speed : 1.00 to 1.5 mt / ps
- Capacity : 06 to 20 passenger
- Car Finish :
 - MS Powder Coated Finish Car.
 - Stainless Steel Hair line Finish Car.
 - Steel Designed & Steel Hair line Finish Car.
 - Steel Mirror & Stainless Steel Hair line Finish Car.
 - Titanium Gold Designed with Stainless Steel Finish Car.
- Type of Door :
 - Center opening. • Telescopic.
- Doors Finish :
 - MS Powder Coated Finish Auto Door.
 - Stainless Steel Hair line Finish Auto Door.
 - Stainless Steel Designed Finish Auto Door.
 - Titanium Gold Designed Finish Auto Door.
 - Glass with Stainless Steel Framed Finish Auto Door.
- Switch Panels Button :
 - Surface Micro Electro Button. • Touch Button.
- Switch Panels Display :
 - Seven Segment Digital LED Display.
 - Digital Dot Matrix Display. • LCD Display.

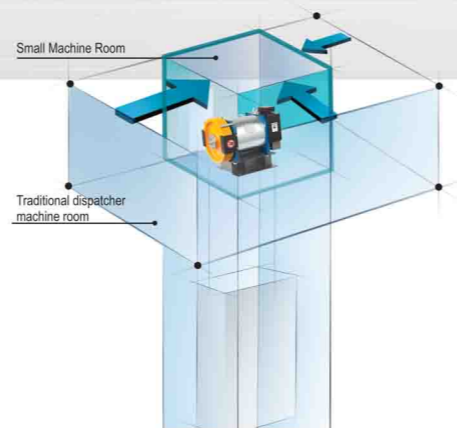

Speed : 1.00 to 1.5 mt / ps
Capacity : 06 to 20 Passenger

Less Space
Less Energy &
More Flexibility



HOISTWAY ELEVATION DRAWING

LIFTING HOOK BY CLIENT
CAPACITY OF LIFT + 1500KGS
BEARING WEIGHT

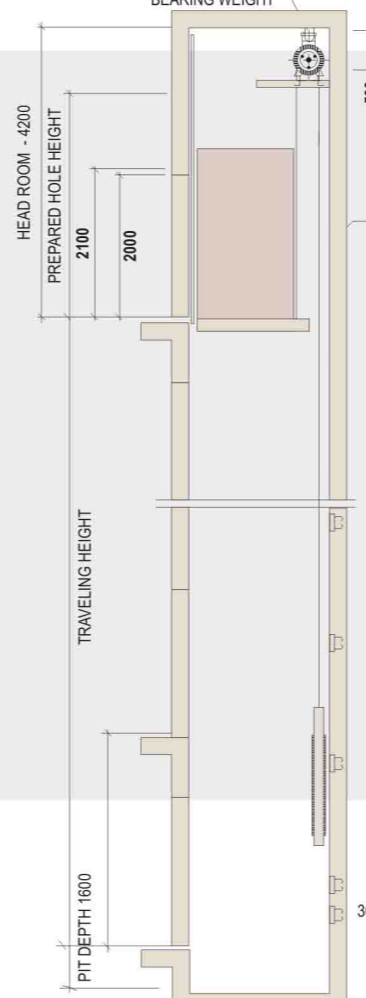

HOISTWAY PLANE LAYOUT

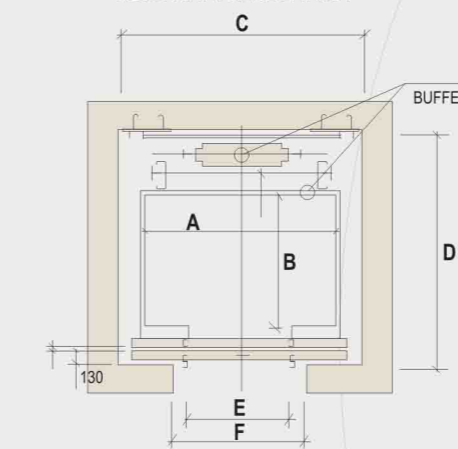

PERSON	CAPACITY KGS	CAR INSIDE		LIFT WELL		CLEAR ENTRANCE	CLEAR OPENING AT LANDING	
		A	B	C	D	E	F AUTO DOOR	F MANUAL TELESCOPIC
6	408	1200	900	1800	1400	700	780 / 2100	1450 / 2350
8	544	1300	1100	1900	1600	800	880 / 2100	1600 / 2350
10	680	1300	1300	1900	1800	800	880 / 2100	1600 / 2350
13	884	1600	1400	2200	1900	900	980 / 2100	1700 / 2350

All Dimensions are in mm.



Home / Bungalows Elevator



Home / Bungalows Elevator



It's Not Just a Lift
It's a Life Style

Home Passenger Elevators for Duplex Flat & Bungalows Saves Machine Room Construction Single phase & Three phase compact design high quality gearless machine unit with latest technology controlling system Depending upon the shaft size with speed/amenities up to choice of owners.



Various options are available :

- Speed : 0.32 mt / ps
- Capacity : 04 to 06 passenger
- Machine Unit :
 - Single Phase. • Three Phase.
- Car Finish :
 - MS Powder Coated Car.
 - Stainless Steel Hair line Finish Car.
 - Steel Designed & Steel Hair line Finish Car.
 - Steel Mirror & Stainless Steel Hair line Finish Car.
 - Titanium Gold Designed with Stainless Steel Finish Car.
- Type of Door :
 - Manual Center opening. • Manual Telescopic.
- Doors Finish :
 - M.S Collapsible Manual Doors.
 - MS Powder Coated Swing Finish Manual Door.
 - MS Powder Coated Telescopic Finish Manual Door.
 - Stainless Steel Hair line Telescopic Finish Manual Door.
 - Stainless Steel Designed Telescopic Finish Manual Door.
 - Titanium Gold Designed Telescopic Finish Manual Door.
 - Glass with Framed Telescopic Finish Manual Door.
- Switch Panels Button :
 - Surface Micro Electro Button. • Touch Button.
- Switch Panels Display :
 - Seven Segment Digital LED Display.
 - Digital Dot Matrix Display. • LCD Display.



MRL Home Lift Gearless Machine Capacity 04 To 06 Passenger

- ▶ Single phase lift operated on 230 volts.
- ▶ High efficient gearless traction machine.
- ▶ Compact design.
- ▶ Eco-friendly.
- ▶ Easy installation and maintenance free.

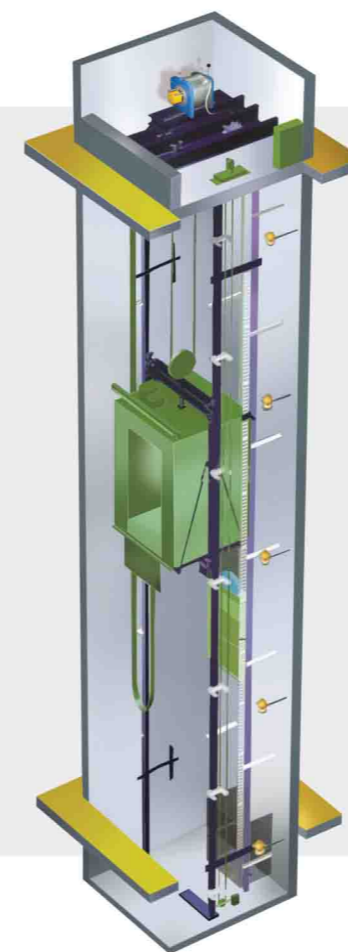

HOISTWAY ELEVATION DRAWING

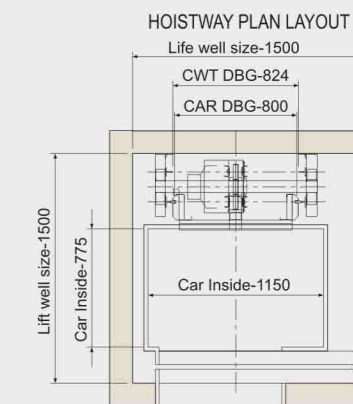
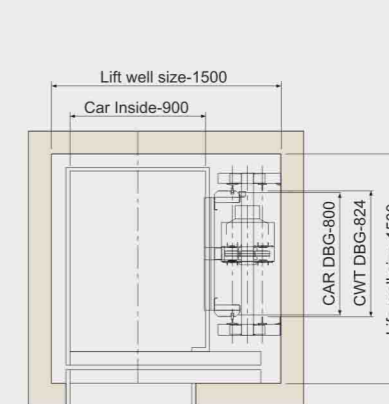
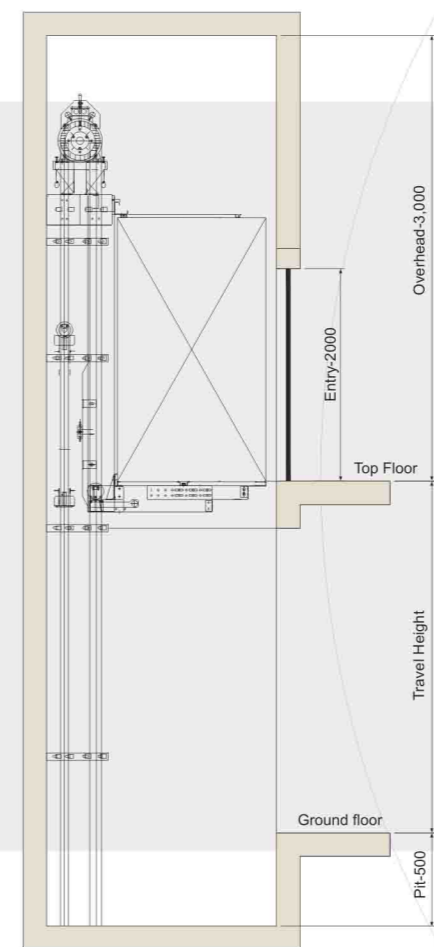

RPM	120	Pulley Dia.	100 mm
FREQUENCY	12 Hz.	Rope Dia.	4 mm
VOLTAGE	230 VAC	No. of Ropes	4
kW / HP	0.75 / 1	Lifting Capacity	300 kg
WEIGHT	70 kg.	Lift Speed	0.32 m/s
BRAKE	Pick-up : 220 VDC	Max. Travel	15 Mts.
VOLTAGE	Holding : 110 VDC	Starts / Day	100

All Dimension are in mm.
This is General Data, it may be changed without notice.



Speed : 0.32 mt / ps
Capacity : 04 to 06 Passenger



Hydraulic Elevator

For Low Rise

Hydraulic Elevator

For Low Rise

Best in Class Eco Efficiency

Hydraulic Passenger / Goods Elevators Manual / Auto door for Residential, Commercial, Hotel, Clubs, Bungalows & Industrial buildings depending upon the shaft size & convenient machine room less movement of men, material & vehicles. With speed / amenities up to choice of owners.

Various options are available :

Speed	0.5 to 1.0 mt / ps
Capacity	6 to 12 passenger
Capacity	500 kg to 5000 kg
Car Finish	MS Powder Coated Car. Steel Designed & Steel Hair line Finish Car. Steel Mirror & Stainless Steel Finish Car. Titanium Gold Designed Car.
Type of Door	• Auto Door. • Manual Doors.
Doors Finish	M.S Collapsible Manual Doors. MS Powder Coated Finish Manual Swing Door. MS Powder Coated Finish Auto Door. Stainless Steel Hair line Finish Auto Door. Stainless Steel Designed Finish Auto Door. Titanium Gold Designed Finish Auto Door. Glass With Stainless Steel Auto Door.
Switch Panels Button	• Surface Micro Electro Button. • Touch Button.
Switch Panels Display	• Seven Segment Digital LED Display. • Digital Dot Matrix Display. • LCD Display.

Features

- ▶ Wide mass range
- ▶ Simple, robust design without mechanical springs.
- ▶ Light weight.
- ▶ Minimum overall height.
- ▶ Technical support and buffer design consultancy.
- ▶ Controlled peak deceleration.

Benefits

- ▶ Minimises inventory.
- ▶ Low unit cost.
- ▶ Long term support.

ROPE TYPE -1

It is a single side indirectly acting suspension with wire ropes having one piston for regular loads and long travels of maximum 12 meters.

Persons	Capacity Kg	Car-W (A)	Card-D (B)	Shaft-W (C)	Shaft-D (D)
3	225	800	900	1300	1300
4	300	850	1050	1350	1450
5	375	1000	1200	1500	1500
6	450	1100	1250	1600	1600
8	600	1200	1500	1750	1800
10	750	1200	1700	1750	2200
12	900	1300	1800	1850	2100
15	1125	1300	2200	1850	2500
20	1600	1400	2500	1950	2800

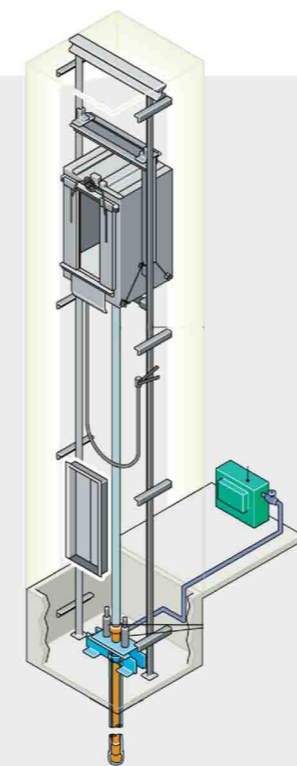

Passenger Elevator Direct System (Bore Type)



Passenger Elevator Side Acting

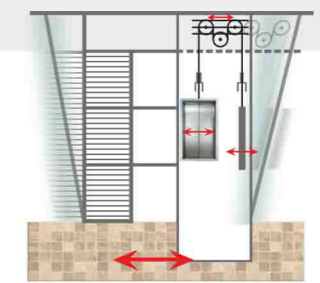
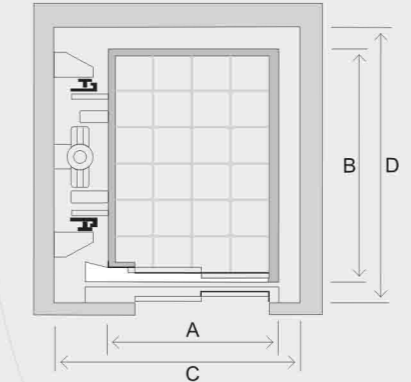

(A) Traction Elevator



(B) Hydraulic Elevator

Outstanding quality
Safe and reliable

Speed : 0.5 to 1.0 mt / ps
Capacity : 06 to 12 Passenger
Capacity : 500 kg to 5000 kg



Optional Cabin Designs



M.S. Powder Coated Finish Car.



Stainless Steel Hairline Finish Car.



Stainless Steel with Mirror Finish Car.



S.S. Etching & Hairline Finish Car



M.S. Powder Coated & Glass Car



S.S. Powder Coated & Glass Car

Optional Cabin Designs



Stainless Steel with M.S. Colour Powder Coated Car.



Stainless Steel with Decorative Etching Finish Car.



Titanium Gold Designed With Stainless Steel Finish Car.



Titanium Gold Finish Car



Titanium Gold & Stainless Steel Mirror Finish Car



Stainless Steel Stripes Etched Finish Car



Designer Sheets



Splendour Maze



Polka Gold



Maple Glory



Gold Square



Gold Hairline



Polka Silver



Vertical Sliver

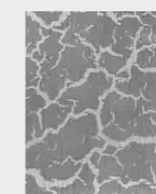

Classic



Silver Square



Silver Hairline

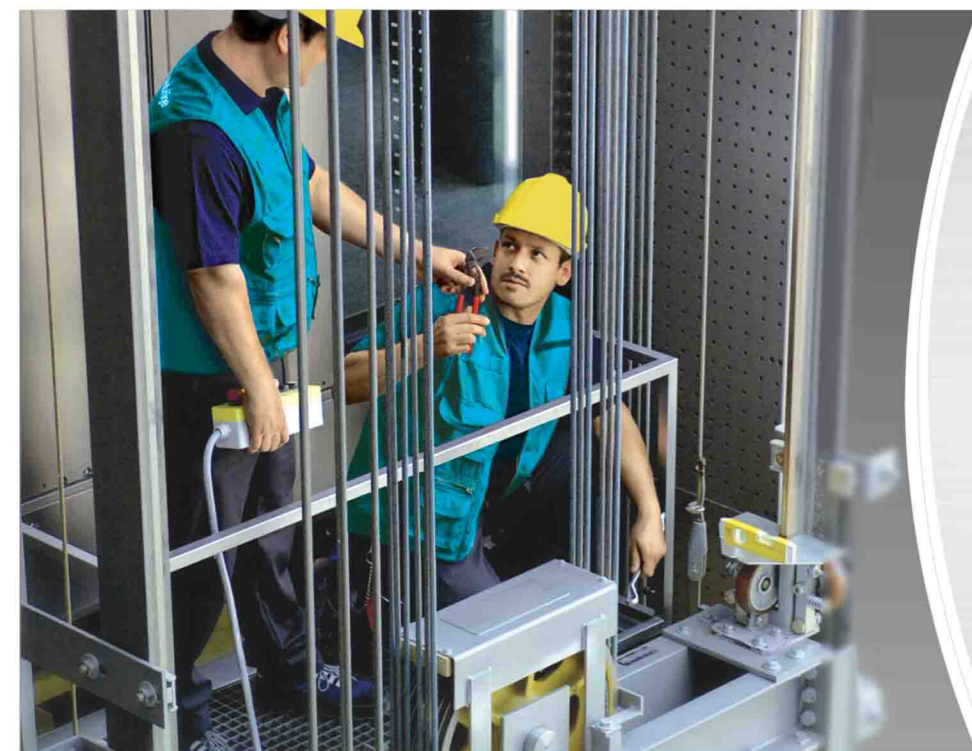

Push Buttons

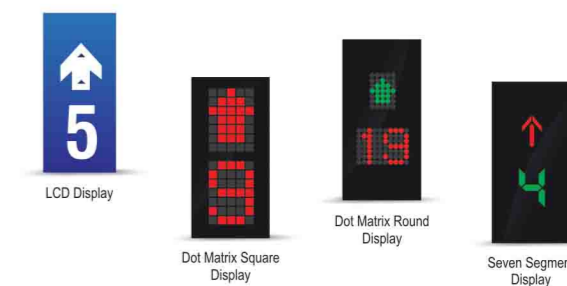

Elevator Machine



Microprocessor High Technology Controls

OCEAN
ELEVATORS

Modernization Geared Machine

TRACTION MOTOR UNIT

The traction units are designed with latest technology to minimize maintenance and noise less units. Fully aligned free units The two centre coils have been provided for stable brake adjustments. Ball bearing motor for smooth & silent operation in empty and full load conditions.



Single Shaft Traction M/C.



Vertical Traction M/C.



Bottom Traction M/C.



Gearless Machine



Mini Gearless Machine

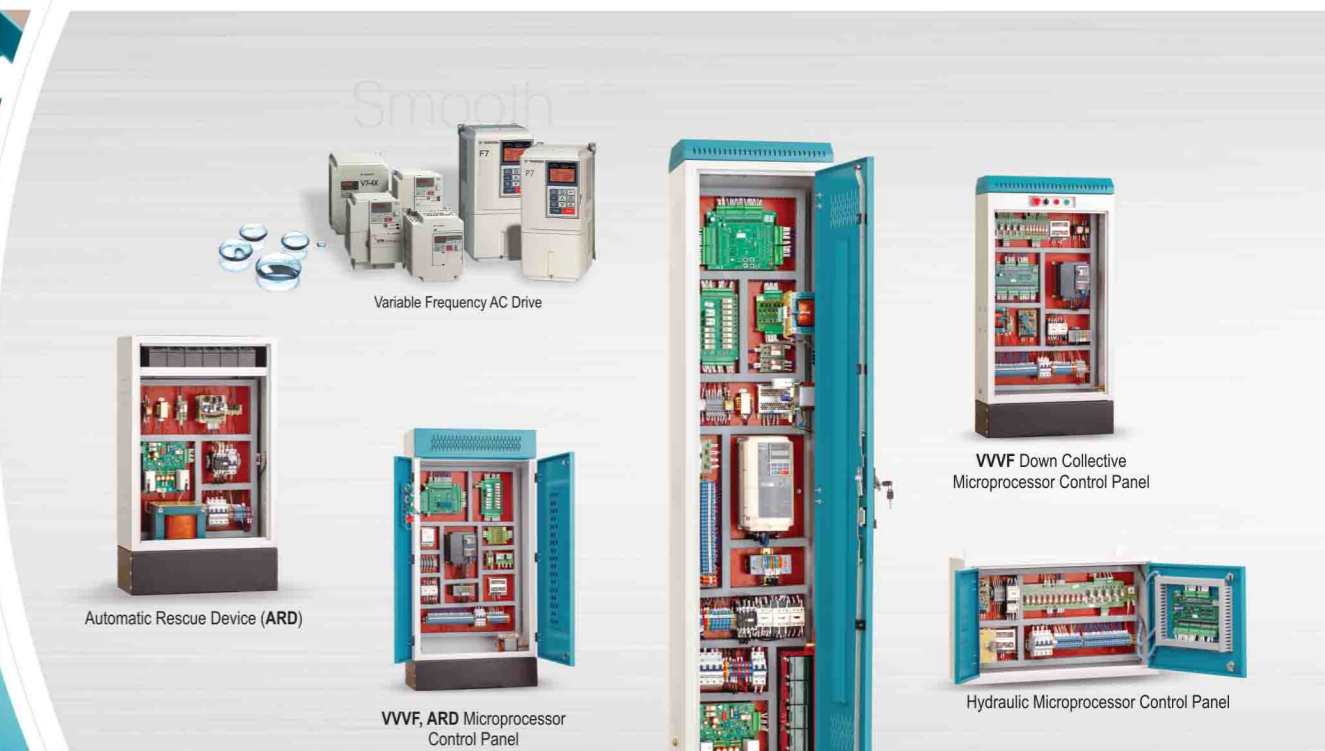
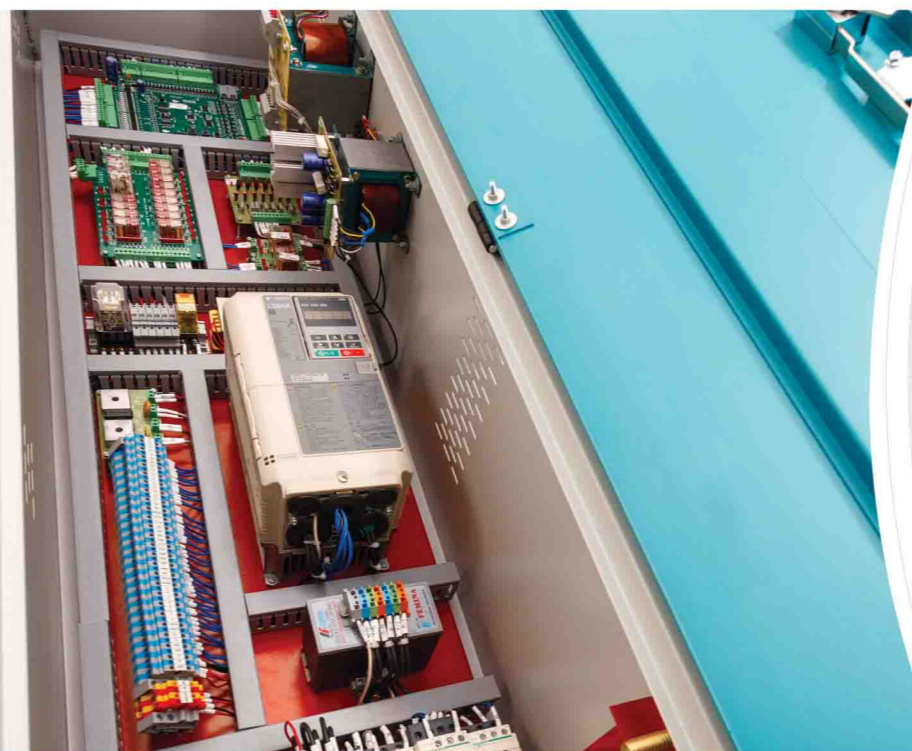

Variable Frequency AC Drive



Automatic Rescue Device (ARD)



VVF, ARD Microprocessor Control Panel



MRL VVF, ARD Microprocessor Panel



VVF Down Collective Microprocessor Control Panel



Hydraulic Microprocessor Control Panel

VVVF Microprocessor based Controller is Designed to fulfill the Customer's Actual needs. It uses latest electronics components and well Designed Software havinh very low Power Consumption. its gives best level accuracy with Very High Response to the passenger call. It is provided with indication for quick and easy diagnosis.

With Machine Room

Without Machine Room

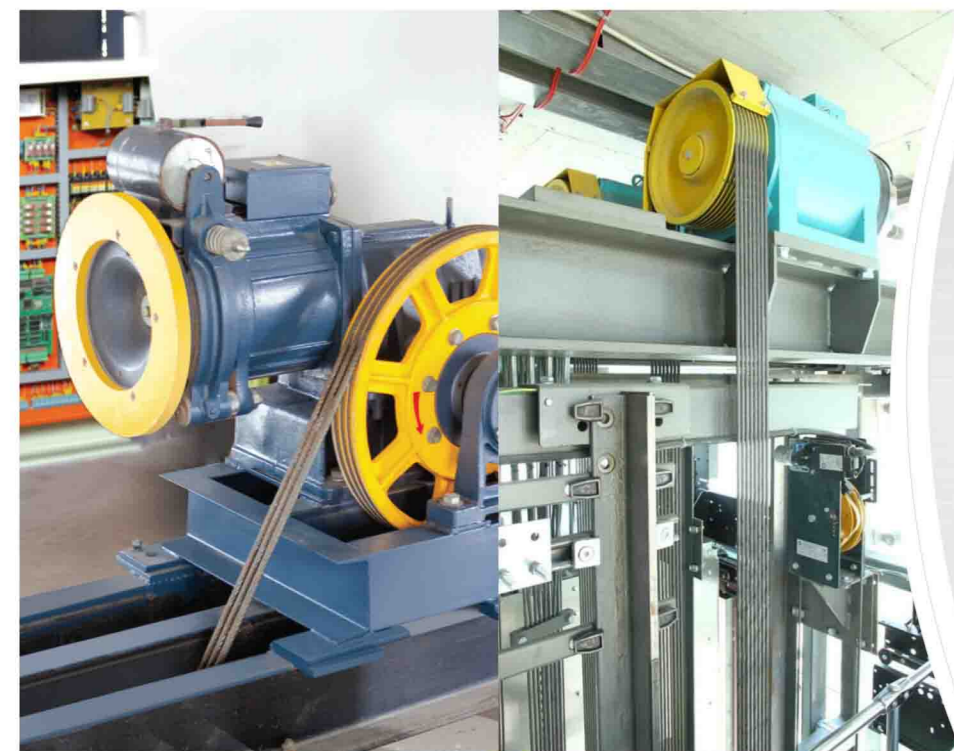

GEARLESS MOTOR UNIT

The OCEAN on machine-room elevator is applicable for passenger elevator, housing elevators, sightseeing elevator or other elevator with carrying capacity no more than 2,000 kg and running speed on more than outdoor steel-structure shaft fame for rebuild buildings.

Your Trusted Industry Automation Solution Provider



Our Elevator Projects

AT SURAT

Our Elevator Projects

AT SURAT

RADHE RESIDENCY

CHARBHUJA ARCADE



MAHAVIR HEIGHTS

ABHINANDAN RESIDENCY

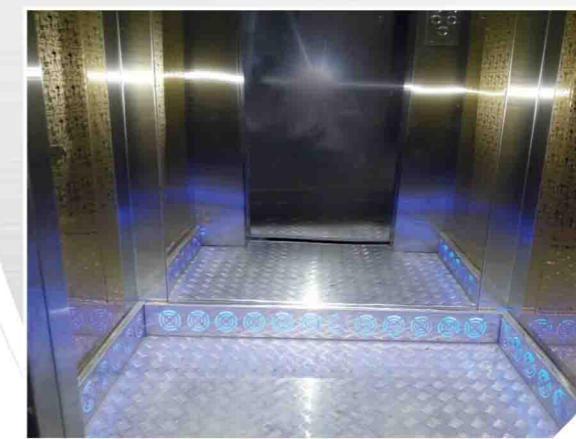

Standard Dimension

Safety Features

Standard Features

- ▶ Overload Non Start
- ▶ Automatic Bypass
- ▶ Door Safety Edge
- ▶ Interphone
- ▶ Emergency Car Lighting
- ▶ Fire Emergency Return
- ▶ Car Light & Fan Automatic Shut Off
- ▶ Anti-Nisance Cancellation
- ▶ Car Call Cancellation
- ▶ Attendant Service
- ▶ Door Photosensor
- ▶ Fireman Operation
- ▶ Next Landing
- ▶ Independent Operation

Optional Features

- ▶ Group Control System
- ▶ Continuity of Service
- ▶ Automatic Parking
- ▶ Peak Traffic Control
- ▶ Non-Service of Specified Floor
- ▶ Passenger-Sensing Doors
- ▶ Liquid Crystal Display (Mono/Full Colour)
- ▶ Ultrasonic Door Sensor
- ▶ Hall Lantern
- ▶ Auxiliary Car Operating Panel
- ▶ Automatic Rescue Device (ARD)
- ▶ Supervisory Panel
- ▶ Pre-level Opening
- ▶ Earthquake Emergency
- ▶ Voice Synthesizer
- ▶ Card Access System
- ▶ Lift Monitoring System
- ▶ Arrival Chime
- ▶ Password Access
- ▶ Fault Records
- ▶ Key Switch Parking Operation
- ▶ Emergency Power Operation

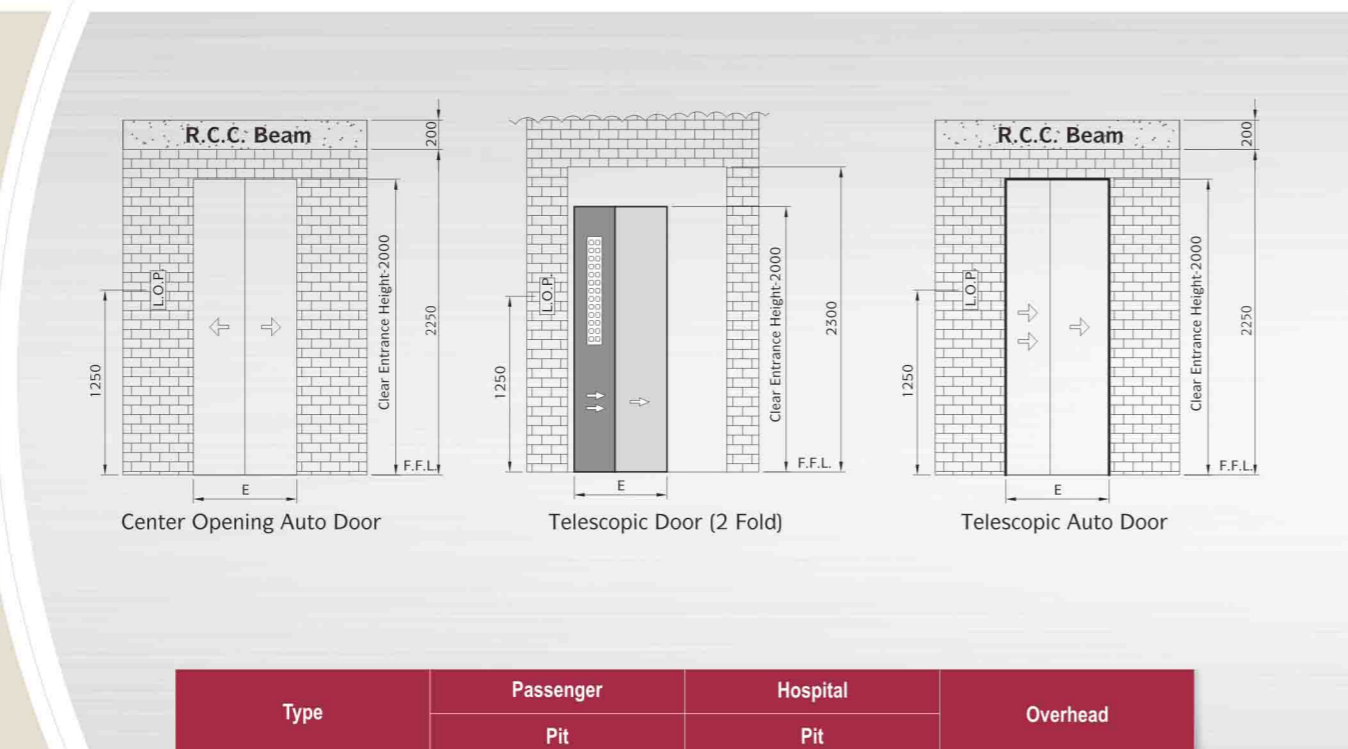

Type	Passenger	Hospital	Overhead
	Pit	Pit	
Hydraulic	1200	1200	3660
Traction	1600	1800	4800
M.R.L.	1600	1800	5000 / 5200

Special Note :
 • All dimensions are in mm.
 • Capsule Lift : Require Pit-1800mm



- ▶ **INFRARED LIGHT CURTAIN**
Full height infra red curtain with multiple cross-crossing light beams detect the smallest obstruction in door path and stop doors from closing.
- ▶ **OVER LOAD SENSOR WITH AUDIO VISUAL INDICATION**
On overloading of the lift, car audio-visual indication is provided and doors are kept open till excess load is removed.
- ▶ **SLOT LESS DOOR SILLS**
Stainless steel lift car is now complimented by matching stainless steel bottom sills. More ever bottom sills are groove less, thus enhancing asthetic appearance of the elevator. No slots for dust to accumulate and obstruct the door. So trouble free operation is ensured. Ensures smooth movement of trolleys & strictures. (Block-C)
- ▶ **CAR EMERGENCY LIGHT & FAN**
The emergency light is always illuminated in normal condition and switches itself automatically to battery back up in case of power failure as shown in picture. (Block-D) Fan also operates for minimum 20 minutes after power failure.
- ▶ **EMERGENCY ALARM & 'PUSH TO TALK'**
In case of any emergency or power failure, help can be obtained by alarming or by communicating at lobby through this system which is battery operated and self charging as shown in picture. (Block-E)
- ▶ **EMERGENCY RESCUE BUTTON**
in the event of power failure, trapped person in lift car rescue themselves by pressing emergency rescue button provided in car panel as shown in picture. (Block-F)
- ▶ **SAFETY IN CASE OF OVER TRAVEL**
Three phase electric power is disconnected from control panel and motor, the moment elevator car moves beyond the limit of top and bottom terminal floors causing immediate application of the brake to bring the elevator to halt.
- ▶ **SAFETY IN CASE OF ROPE BREAKAGE**
In the elevator of breakage of ropes, elevator speed exceeds the rated speed in the downward direction due to gravitational acceleration. the over speed governor activates the clutch mechanism thereby switching off main controls and jamming the elevator car safety on guide rails.
- ▶ **PU BUFFERS**
Polyurethane polymer blocks are long lasting, weather resistant and most reliable in all operating Conditions for providing maximum safety in case of buffering of elevator car.
- ▶ **CAR FAN AUTOMATIC SLEEP**
Car fan automatically stops when there are no registered floor calls resulting into saving in power and enhancing its life.
- ▶ **VOICE ANNUNCIATOR WITH MUSIC**
This system provides detailed information to passengers related to next floor, direction of movement, door opening/closing, scheduled operations and other information depending on the building needs. This system features natural electronic voice synthesizers.
- ▶ **MICROPROCESSOR BASED V3F (VARIABLE VOLTAGE, VARIABLE FREQUENCY), VECTOR CONTROLLED DRIVE WITH ENCODER FEEDBACK CLOSED LOOP SYSTEM DOOR OPERATION.**
This system reduces the door opening and closing time drastically compared to conventional door operation system thereby improving the passenger handling capacity and reducing the waiting time at landing.

Contact

OCEAN ELEVATORS PVT. LTD.

Head Office & Factory

Ahmadabad :

115, Sidhdhivinayak Complex, Opp. Tejendra Complex,
Nirant Char Rasta Vastral, Ahmedabad – 382418
Mobile : + 91 99985 06886, 98250 45178, 98256 41572
Office Phone : + 91 79 6524 1616

Factory :

77, Yamuna Esate Part 1, Nr. Sakriba Party Plot C.T.M.
Ahmadabad
Mobile : + 91 9825011572, Phone : + 91 79 2585 7362.
E-mail : oceanelevators786@yahoo.com
Website : www.oceanelevators.com
F : ocean Elevators

Surat Factory & Office :

Plot No : A 23/19 Road No 13, Near Shiva Foundry,
Udhana, Uddhyognagar, Surat
Mobile : + 91 98256 41572, 97270 23772, 80000 55666,
Phone : 0261 6534786

Branches in Gujarat

Ankleswer : + 91 9879382862 Baroda : + 91 97370 23772 Bharuch : + 91 9904041786
Navsari : + 91 9099457076 Valsad : + 91 9898818574 Vapi : + 91 90994 57076

Branches in India

BOKARO :

L. H. More Sonatand, Near Shiv Mander, Post - Siwandhi, Bokaro Steel City
Mobile : + 91 93080 35291, 99341 35425

DELHI	Mobile : + 91 98680 47011, 98390 64444
JHARKHAND	Mobile : + 91 93080 35291
KOLKATA	Mobile : + 91 99985 06886, 96818 92188, 81006 26649
KANPUR	Mobile : + 91 94151 23558, 97923 62134
LUCKHNOW	Mobile : + 91 99847 20420, Office : 0522 6500246
ORISSA	Mobile : + 91 93373 36988
PATNA	Mobile : + 91 93048 26813, 93048 85654, Office : 0612 2279997
RANCHI	Mobile : + 91 93344 33058
UDAIPUR	Mobile : + 91 99985 06886, 98250 45178
VARANASI	Mobile : + 91 9721400420



INNOVATE
THROUGH MOTIVATION



(ISO 9001 : 2008 / REGD : G/SZ/EML/00067)

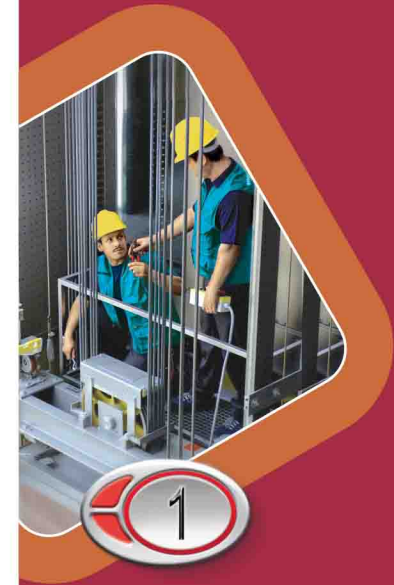

Head Office :

115, Sidhdhivinayak Complex, Opp. Tejendra Complex,
Nirant Char Rasta, Vastral, Ahmedabad - 382418

Phone : 079 6524 1616

Mobile : + 91 99985 06886, 98250 45178

E-mail : info.oceanelevators@gmail.com

Surat Office & Works :

A - 23 / 19, Road No 13, Near Siva Foundry,
Udhna, Udhyanagar, Surat - 394 210

Mobile : + 91 98256 41572, 98250 11572,
97270 23772, 80000 55666

Phone : 0261 - 6534 786

E-mail : oceanelevators786@yahoo.com

Website : www.oceanelevators.com

